

PS 12L / PS 16L / PS 20L



Electric Pedestrian Stacker with capacities of 1200/ 1600/ 2000kg

- Ergonomic, Compact and Safe Long Tiller Design
- Precise Lifting and Lowering with Full Proportional Hydraulic System
- Powerful, Maintenance Free German AC Power Train
- Core Components from Top Quality Brands
- 4 Wheel Structure for Stability

INTRODUCTION

The PS 12- 20L series is tailored to most pedestrian controlled stacking operations with capacities from 1200kg up to 2000kg.

With the long mounted tiller the operator keeps safe and ergonomic distance to perform his work.

Due to the gentle operating full proportional lifting system stacking operations becomes more safer and quicker.

With the high- quality and state of the art top-brand components and technologies, the truck competes with leading well- known brands in the market.

Top brand qualified components

Using high quality core components:

- Reliable multifunctional REMA tiller with ergonomic contact less rocker- switches
- Top quality Schabmueller AC drive motor
- Kordel gearbox
- HPI hydraulic power pack
- Zapi controller
- Intorque brake
- Wicke drive wheel

The used parts reduce high service costs and give you the performance and reliability which is required for the demanding stacking operations.



PS 16L



Long tiller design for ergonomics and safety

In particular through the long tiller design the operator can always keep a safe distance to the truck during proceeding the work very ergonomically. The design ensures lower operational forces than trucks with a short tiller. The tillers operating height is naturally positioned to ergonomic, operator friendly controlling positions.

Specifically staking operations becomes more ergonomically and quicker due to the safe distance and better view to the forks. The 4 wheel design with the sideways long mounted tiller gives particular an exact and perfect view to the forks.

Electronic proportional lifting and lowering

The electronically controlled proportional lifting system ensures accurate positioning and stacking operations at every lifting height.

In specific with high masts the electronic controlled proportional lifting performs at its best.



CAN-BUS

CANBUS technology

The CANBUS technology is due to less wiring more reliable.

For maintenance the CANBUS technology makes analysis and adjustments easier so that the downtime is lower than for trucks without CANBUS.

Digital signals further makes parts longer lasting than analogue signals.



Robust and Reliable Design

The robust chassis with the strong 8mm thick apron protects the truck and the components against mechanical impacts from the outside.

In combination with the metal battery cover, the truck is well- equipped to reduce maintenance work and damages to a minimum.

Dirty floor environments have less influence to the vertical AC motor design as the components and the brake are out of the reach of direct impacts.

IP 54 protected controller, safe against dust and splash water.



German AC drive technology

The powerful German Schabmueller maintenance free AC Drive motor in combination with the German Kordel gearbox, Intorque brake and Wicke drive wheel give best performance, efficiency and reliability to reduce the running costs!

Whether smooth or fast acceleration is applied, the AC Drive gives always the right and direct response.



Maintenance friendly

The trucks design and the used components are tailored to make service and maintenance easy. All components are easy to reach when removing the main cover only with 2 screws. The drive wheel and the castor wheel are easy to exchange without craning the truck.



For every application the right battery capacity

With the PS-L series for every truck the right battery:

- PS 12L with 180 Ah 2VBS battery for short truck length, good maneuverability and for operating restricted areas.
- PS 16L with 270 Ah 3VBS battery
- PS 20L with 350 AH DIN 3PzS battery for long operations and multi- shifts.



Optional sideways battery exchange compartment for PT20L with 210 Ah battery.

Options

- Various mast versions
- Load backrest
- Sideways battery exchange for PS 16L and PS 20L

PS 20L



Designation	Lowered mast height h1(mm)	Free Lift height h2(mm)	Lift height h3(mm)	Extended mast height h4(mm)	Lift+fork height h3+h13(mm)
PS 12L					
Two stage mast	1958	--	2830	3380	2920
	2108	--	3130	3680	3220
	2308	--	3530	4080	3620
Two stage mast FFL (Full-Free-Lift)	1958	1410	2830	3380	2920
	2108	1560	3130	3680	3220
	2308	1760	3530	4080	3620
PS 16L					
Two stage mast	1958	--	2830	3380	2920
	2108	--	3130	3680	3220
	2308	--	3530	4080	3620
Two stage mast FFL (Full-Free-Lift)	1958	1410	2830	3380	2920
	2108	1560	3130	3680	3220
	2308	1760	3530	4080	3620
Three stage mast	2008	--	4230	4780	4320
	2108	--	4530	5080	4620
Three stage mast FFL (Full-Free-Lift)	1908	1320	3930	4480	4020
	2008	1420	4230	4780	4320
	2108	1520	4530	5080	4620
	2343	1756	5230	5780	5320
PS 20L					
Two stage mast	2078	--	2830	3500	2920
	2228	--	3130	3800	3220
	2428	--	3530	4200	3620
Two stage mast FFL (Full-Free-Lift)	1978	1310	2630	3300	2720
	2078	1410	2830	3500	2920
	2228	1560	3130	3800	3220
	2428	1760	3530	4200	3620
Three stage mast	2128	--	4230	4900	4320
	2228	--	4530	5200	4620
Three stage mast FFL (Full-Free-Lift)	1978	1310	3930	4600	4020
	2128	1420	4230	4900	4320
	2228	1520	4530	5200	4620

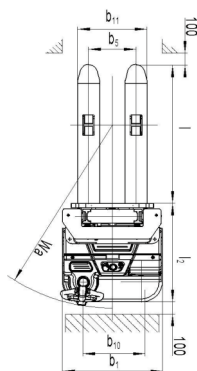
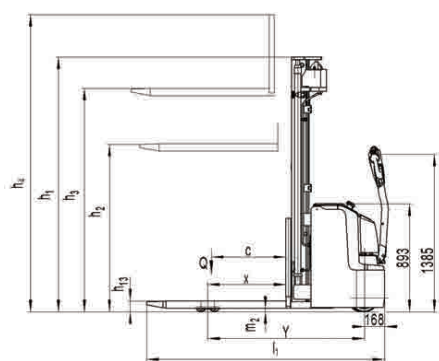

Type sheet for industrial truck acc. to VDI 2198 116G=2.2LB 11NCH=25.4MM							
Distinguishing mark	1.2	Manufacturer's type designation		PS 12L(3600)	PS 16L(4600)	PS 20L(4600)	
	1.3	Power (battery /diesel, petrol, gas, manual)			Battery		
	1.4	Operator type			Pedestrian		
	1.5	Load Capacity / rated load		1.2	1.6	2.0	
	1.6	Load centre distance	Q(t)		600		
	1.8	Load distance ,centre of drive axle to fork	c(mm)		647		
	1.9	Wheelbase	x(mm)		1248	1429	
	2.1	Service weight	Y(mm)		1007	1340	1579
	2.2	Axle loading, laden front/rear	kg		684/1523	930/2010	1000/2579
2.3	Axle loading, unladen front/rear	kg		610/397	850/490	900/679	
Weight	3.1	Tires		Polyurethane (PU)			
	3.2	Tire size, front	Øx w (mm)	Ø230×70			
	3.3	Tire size, rear	Øx w (mm)	Ø85×75			
	3.4	Additional wheels(dimensions)	Øx w (mm)	Ø150×54			
	3.5	Wheels, number front/rear(x=driven wheels)		1x+1/4			
	3.6	Track, front	b10mm	522			
	3.7	Track, rear	b11 (mm)	390/505			
Tires, chassis	4.2	Lowered mast height	h1 (mm)	2308	2108	2228	
	4.3	Free Lift height	h2 (mm)	1760	1520	1520	
	4.4	Lift height	h3 (mm)	3600	4600	4600	
	4.5	Extended mast height	h4 (mm)	4088	5088	5208	
	4.9	Height of tiller in drive position min./ max.	h14mm		850/1385		
	4.15	Height, lowered t	h13mm		90		
	4.19	Overall length	l1mm	1919	1964	2100	
	4.20	Length to face of forks	l2mm	769	814	950	
	4.21	Overall width	b1mm		820		
	4.22	Fork dimensions	s/e/l (mm)		60/180/1150		
	4.25	Distance between fork-arms	b5 (mm)		570/685		
	4.32	Ground clearance, centre of wheelbase	m2mm	28	28	23	
	4.33	Aisle width for pallets 1000X1200 crossways	As1 (mm)	2336	2406	2536	
	4.34	Aisle width for pallets 800X1200 lengthways	As1 (mm)	2456	2393	2523	
	4.35	Turning radius	Wa (mm)	1440	1510	1640	
Dimensions	5.1	Travel speed, laden/unladen	km/h	6.0/6.0	5.7/6.0	5.4/6.0	
	5.2	Lift speed, laden/unladen	m/s	0.10/0.17	0.13/0.20	0.13/0.20	
	5.3	Lowering speed, laden/unladen	m/s	0.11/0.11	0.20/0.14	0.20/0.14	
	5.8	Max. gradeability, laden/unladen	%	6/12	6/12	6/10	
	5.10	Service brake		Electromagnetic			
Performance data	6.1	Drive motor rating S2 60min	kW	1.3	1.3	1.7	
	6.2	Lift motor rating at S3 4.5%	kW	1.5	3.2	3.2	
	6.3	Battery acc. to DIN 43531/35/36 A, B, C, no		2VBS	3VBS	3PZS	
	6.4	Battery voltage, nominal capacity K5	V/Ah	24/180	24/270	24/350	
	6.5	Battery weight	kWh/h	175	230	288	
	6.6	Energy consumption acc. to VDI cycle		0.95	1.59	1.70	
Electric-engine	8.1	Type of drive control	dB(A)	A.C.-speed control			
	8.4	Sound level at driver's ear acc. to EN 12053		<70			
Additional data							